



Urea Service Valves



Urea Service Valves



 Achilles Joint Qualification System
 for suppliers to the Oil Industry in Norway and Denmark
Certificate of Qualification
 Awarded to
DOUGLAS CHERO S.P.A.
 Achilles Id. 24773
 Achilles Information Centre hereby confirms that
DOUGLAS CHERO S.P.A.
 is qualified in the Achilles Joint Qualification System
 for suppliers to the Oil Industry in Norway and Denmark.
 The qualification concerns the product and service
 categories listed in the appendix.



TUV RWTUV Italian Branch
CERTIFICATE
 Nr. 090908
 Technical instruction on Nr. 3.1.B.4 (1/01)
 We hereby certify that the below listed item has been according to:
 Allgemeine VWV zum Bundes-Immissionsschutzgesetz (BImSchG) with satisfactory result.
 Company: **DOUGLAS CHERO**
 Address: **LOC. PRADAGUE, CARPANETO PIVO (PC) - ITALY**
 Item type: **GATE GLOBE STEAM PACKING SEAL CASSET, PING GRAPHITE TYPE**
 Seal type: **PIG, T400L, PIG, T400L**
 Valve rating: **100 + 4500**
 Drawing: **PIG, T400L, PIG, T400L, PIG, T400L**
 Issued Date: **26-nov-2001**
 Expiry Date: **15-Dec-2002**
 RWTUV Italian Branch Office
 Antonio La Ferla

TUV CERT
CERTIFICATE
 RWTUV CERT
 Issued by the company
 Douglas Chero S.p.A.
 2013 Carpaneto Piacentino (PC) - Italy
 has provided verification of compliance with the conditions in
AD-Merkblatt HP 0 / TRD 201
 according to:
 The conditions for proper fabrication and testing, as well as the conditions for proper installation and commissioning of the product.
 The scope of this verification as well as details concerning the water seal design can be found in the report 3.1.3.1440/01 dated 23.08.1999.
 RWTUV
 2000, 21.08.1999



Douglas Chero S.p.A.

Stablished in 1974,
in the industrial area
of Carpaneto Piacentino, Piacenza.

20 years experience
in Urea Service Valves.

The factory covers an area
of 30,000 m²
(of which 9,000 m² are building).

Urea Service Valves



All forged pieces are made in ASTM A182/F316L modified stainless steel and are bought from approved manufacturers.

Valves can also be made in different materials, according to customer's requirements.

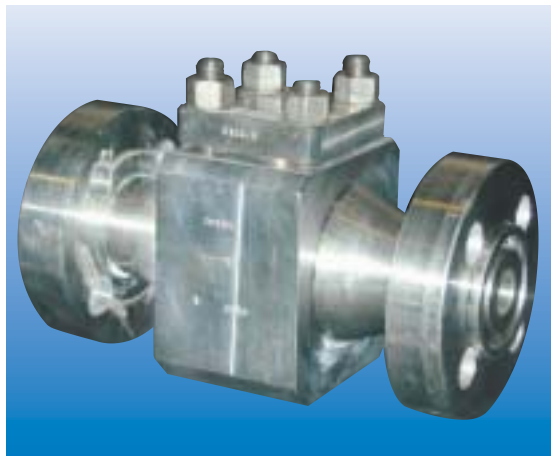

Urea Service Valves



Douglas Chero makes different type of urea valves, like block (straight type), angle type, piston type and drop check, size up to 8" included.

Rating: class 2500 LBS,
P.N. 325 and P.N. 455.



On this page and in the next one,
a short view of our facilities.

Urea Service Valves



Urea Service Valves

Angle block valve UREA service P.N. 325 Male threaded NPSM

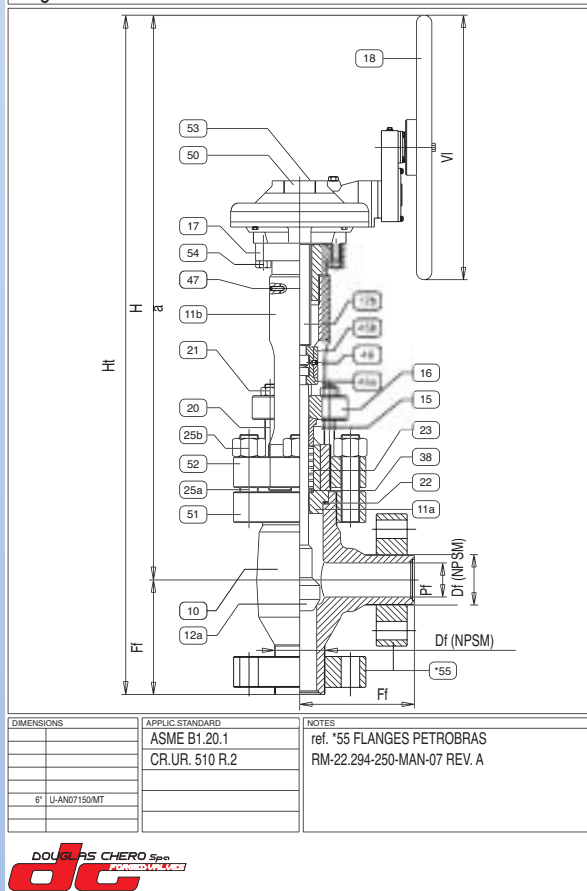

Piston check UREA SERVICE - 2500 - Full B. - Bolted - RJ

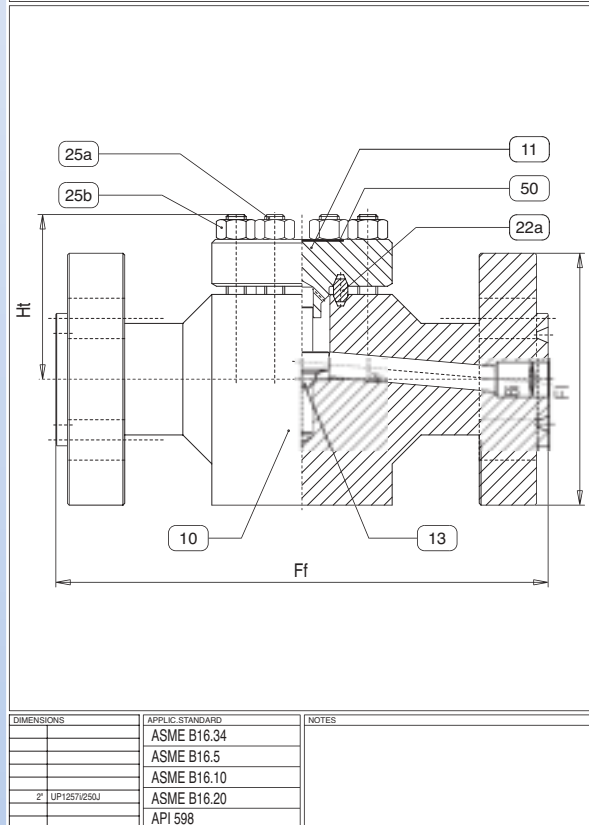

Angle block valve UREA service P.N. 325 Male threaded NPSM

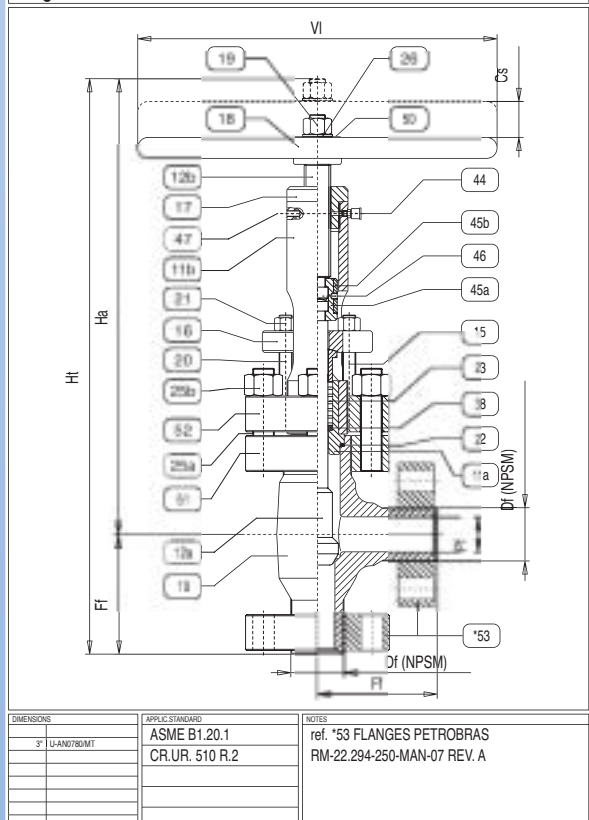

Detailed drawings for each type of valve are issued complete of parts and materials list.

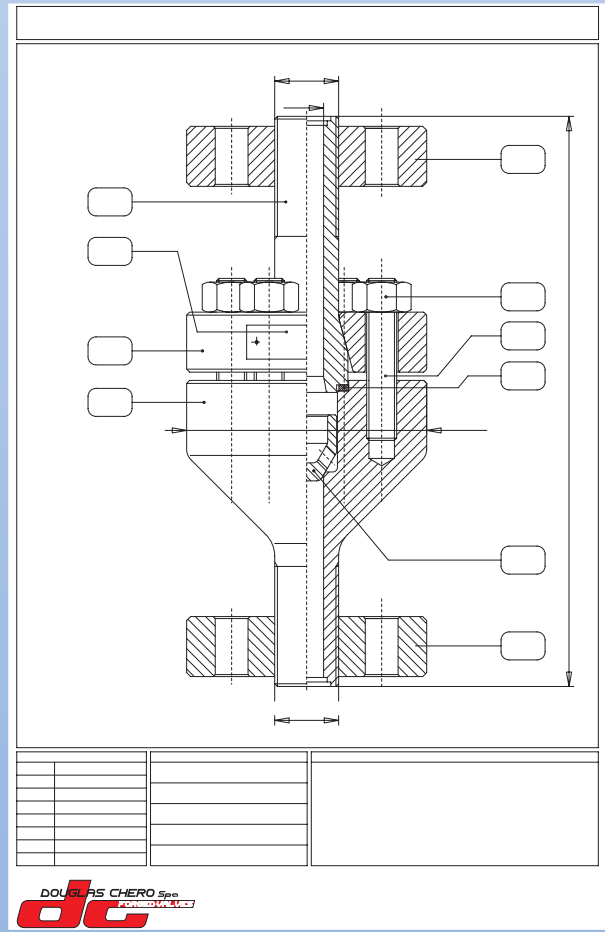
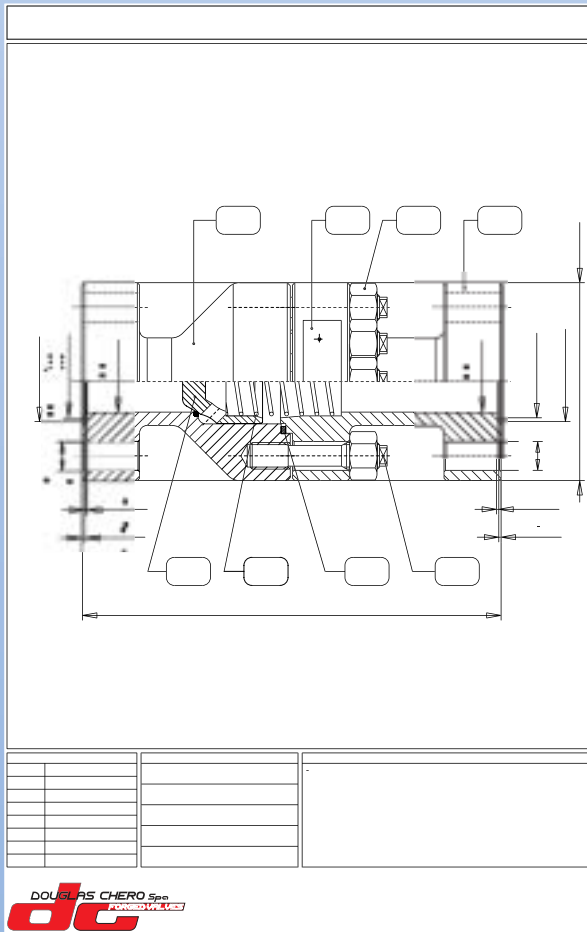
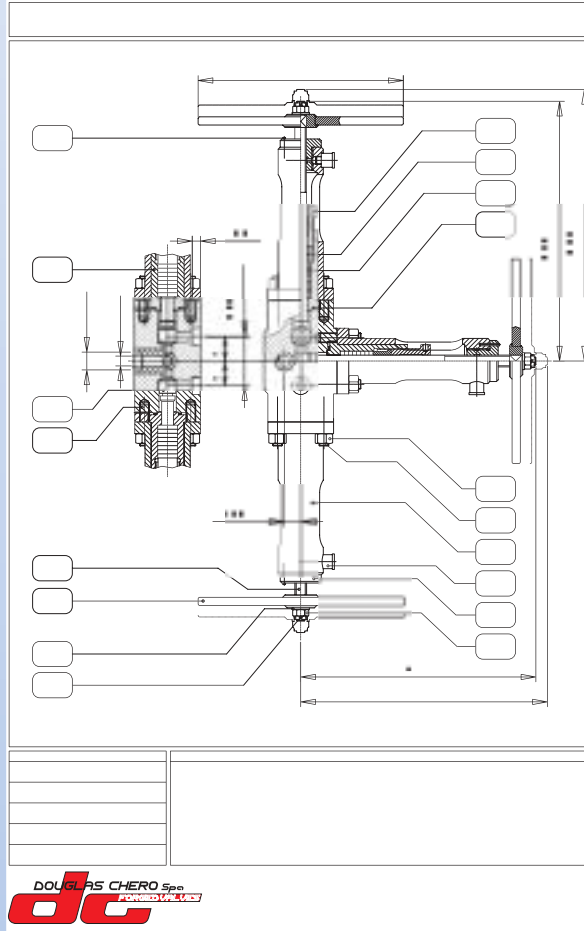

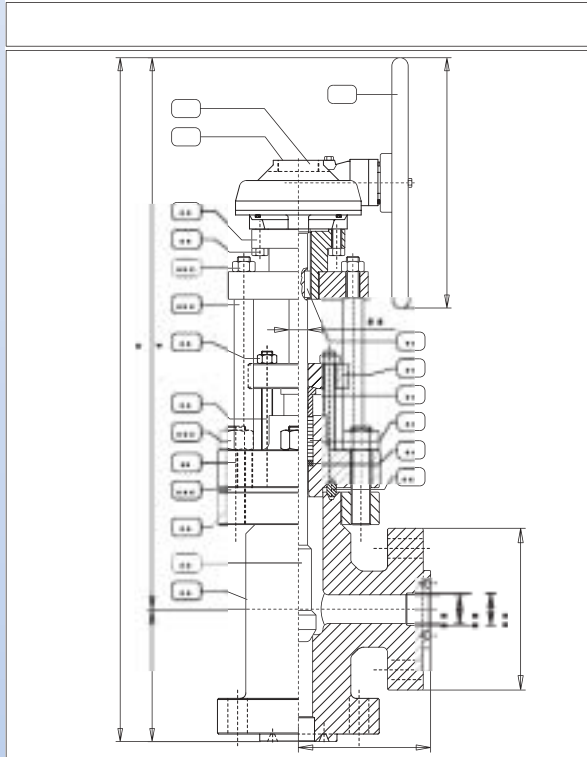

..		

DOUGLAS CHERO SpA
dc FORGED VALVES

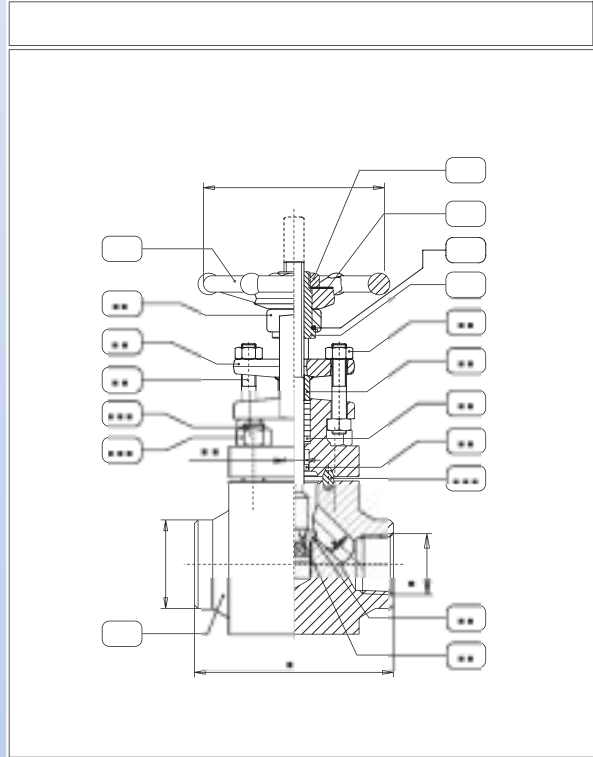

DOUGLAS CHERO SpA
dc FORGED VALVES

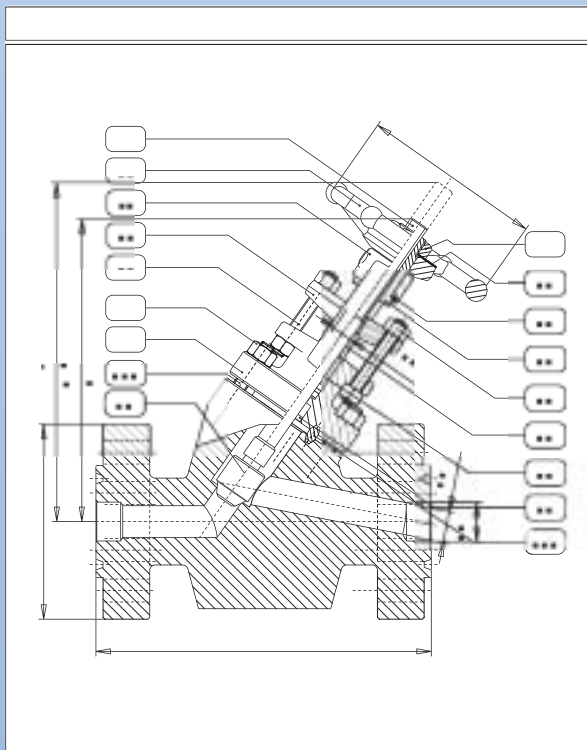

DOUGLAS CHERO SpA
dc FORGED VALVES

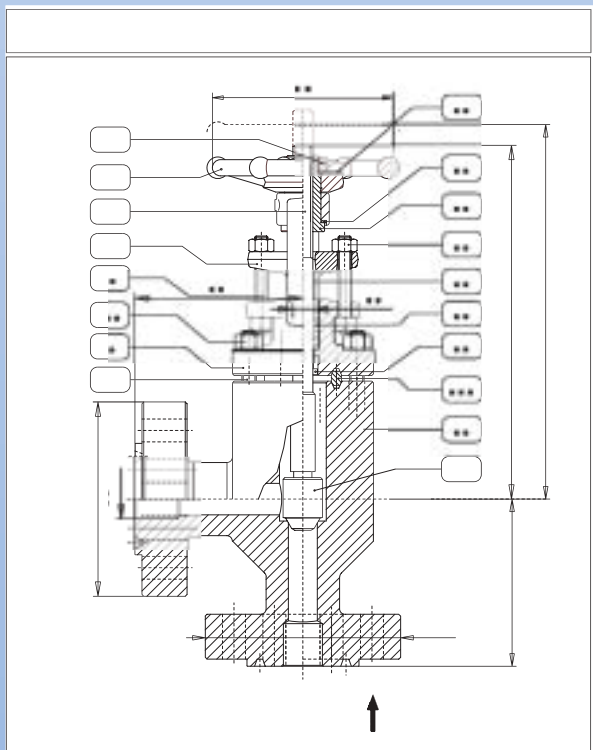

DOUGLAS CHERO SpA
dc FORGED VALVES



Microstructure examination

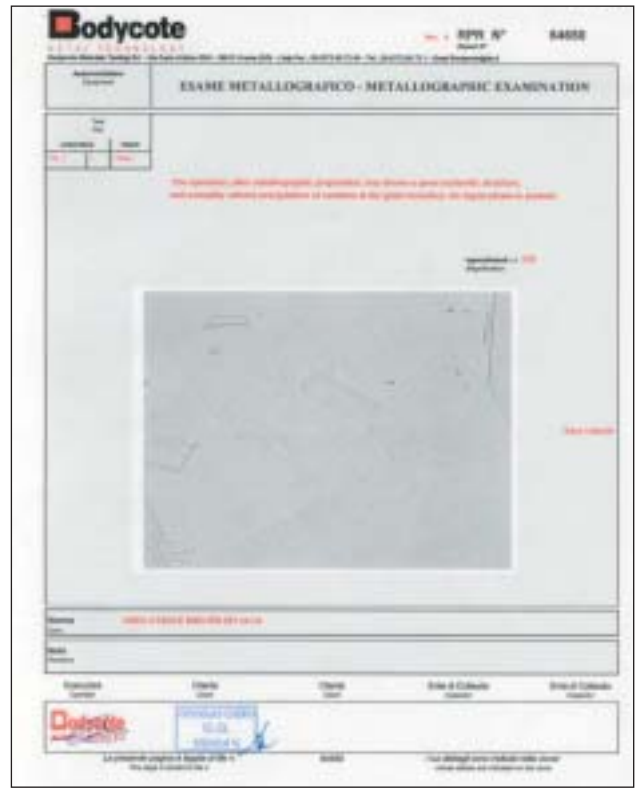

Heat treatment list

All semi-worked pieces are carefully heat treated, in order do not remove more that five millimeters on the finished pieces.

Heat treatment diagram

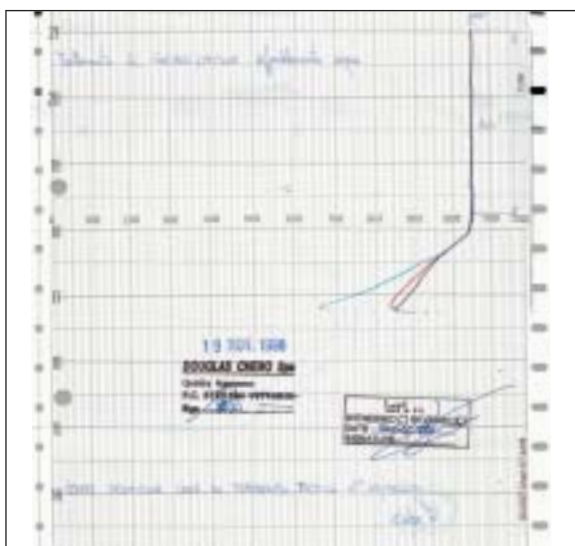

Huey test certificate



Urea Service Valves

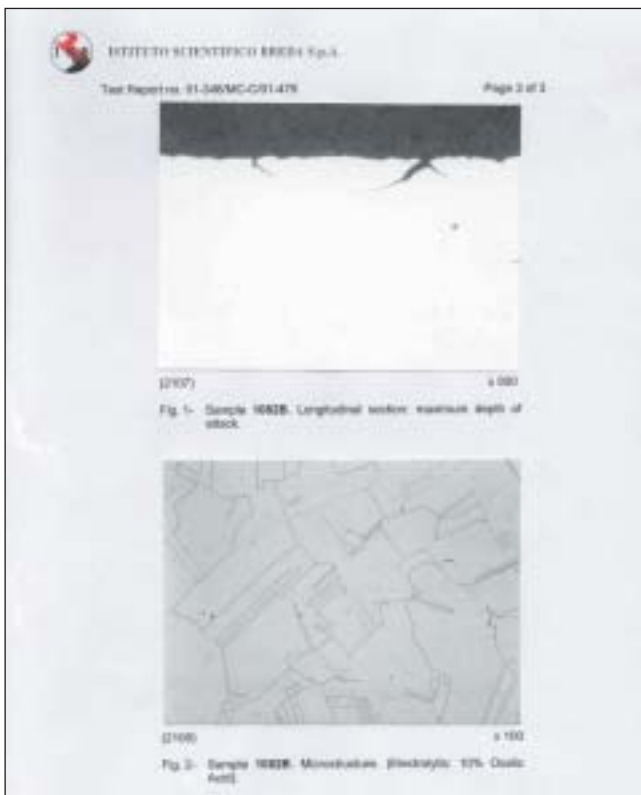

Severe tests are made in order to verify the good corrosion resistance and microstructure type of the material.

Each sample of material is put in a corrosive bath for five cycles, and each cycle lasts 48 hours.

At the end of each cycle, the sample is weighed using a scale capable to weigh up four numbers after the zero.

At the end of test, the sample is micrographic and metallographic examined.



Urea Service Valves

REFERENCE LIST

Country	Customer	Location Plant	Engineering
CHINA	C.N.C.C.C.	Beijing Chemical Ex.	Direct
CHINA	C.N.C.C.C.	Luoyang Chemical Fert.	Direct
CHINA	C.N.C.C.C.	Xuanhua Chemical Fert.	Direct
CHINA	C.N.C.C.C.	Yuanping Chemical Fert.	Direct
CHINA	C.N.T.I.C.	Nanjing	Snamprogetti
CHINA	C.N.C.C.C.	Xuanhua Chemical Fert.	Snamprogetti
CHINA	C.N.C.C.C.	Beijing Chemical Ex.	Snamprogetti
CHINA	C.N.C.C.C.	Luoyang Chemical Fert.	Snamprogetti
CHINA	C.N.C.C.C.	Yuanping Chemical Fert.	Snamprogetti
CHINA	Huainan G.C.	Huainan	Snamprogetti
ARGENTINA	Profertil	Bahia blanca	Snamprogetti/Techint
BRAZIL	Petrobras	Fafen	Urea Casale
BRAZIL	Petrobras	Camacari	Urea Casale
BRAZIL	Petrobras	Various revamping	Urea Casale
KUWAIT	P.I.C.	Debottlenecking & Granular Proj. Mpd-3	Tecnimont
PAKISTAN	Fauji Fert. Co.	Goth Machi	Snamprogetti
INDIA	Tata Chemicals	Babrala	Snamprogetti
INDIA	Tata Chemicals	Budaun	Snamprogetti

Urea Service Valves

FORGED FITTINGS UREA GRADE
AVAILABLE BY CHERO PIPING SPA

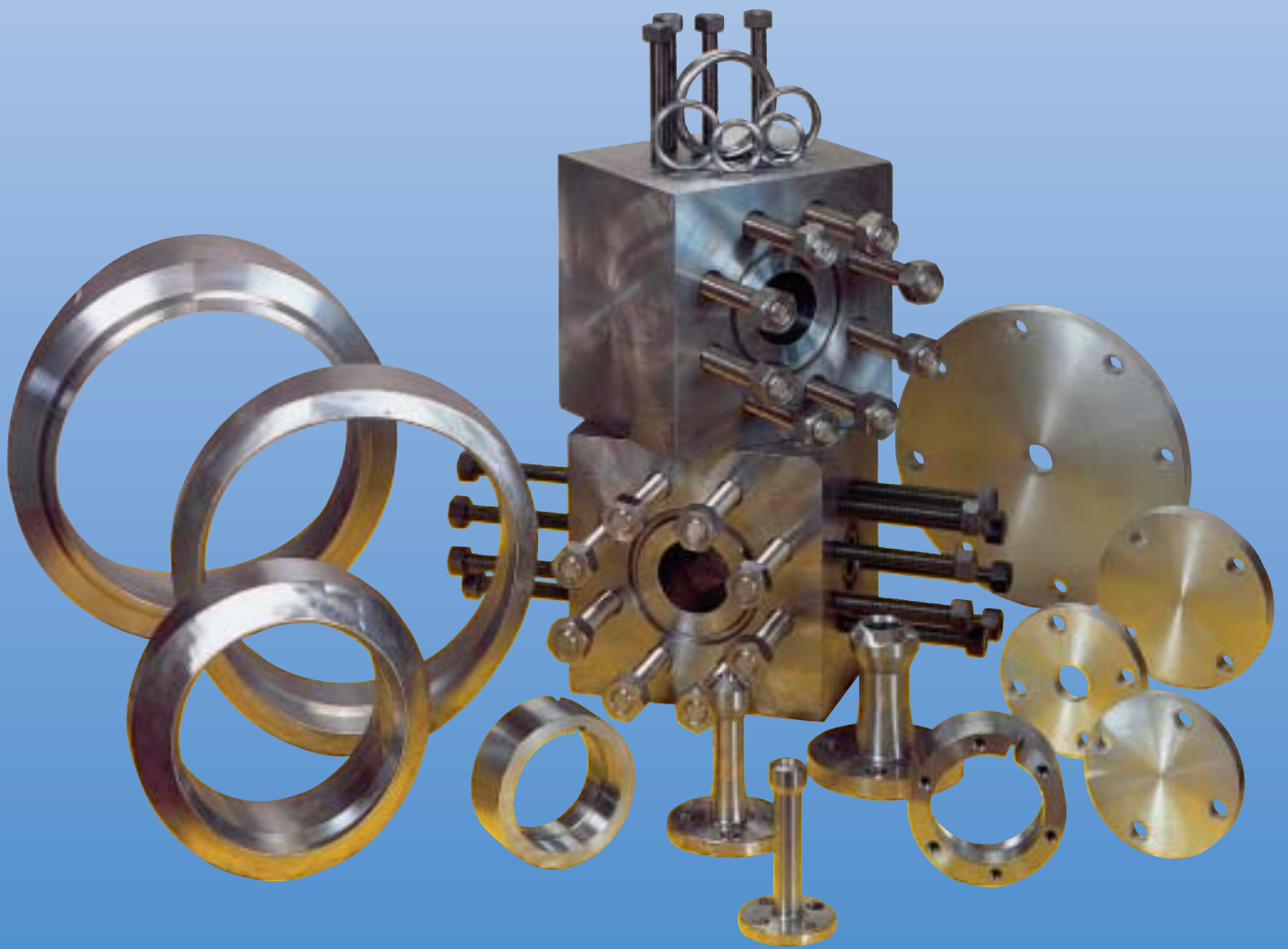

Urea Service Valves



CE certified N° CE-PED-H-DCH001-01-ITA

Douglas Chero S.p.A.

Factory: Loc. Pradaglie - 29013 Carpaneto P.no (PC) - Italy
Ph. 0523.850047 - Fax 0523.850389

E-mail:

Q.C. office: qual.vito@douglas-chero.com
Tech. office: utec.guido@douglas-chero.com
Comm. office: comm.anna@douglas-chero.com
Prod. office: prod.massari@douglas-chero.com